

GRU A MONTAGGIO RAPIDO
 GRUE A MONTAGE RAPIDE
 GRUA DE RAPIDO MONTAJE
 GRUA DE MONTAGEM RAPIDA
 QUICK SELFRECTING CRANE
 HYDRAULISCHER SCHNELLMONTAGEKRAN

Curve di carico – Courbes de charges – Load diagrams – LastKurven – Curvas de cargas

| | | | | | | | | | | | | | | | | |
|---|---|------|------|------|------|------|-----|---|------|---|------|------|-----|-----|----|--|
|  | <table border="1"> <tr> <td>3</td> <td>19</td> <td>21</td> <td rowspan="2">m</td> </tr> <tr> <td>1800</td> <td>850</td> <td>700</td> <td>kg</td> </tr> </table> | 3 | 19 | 21 | m | 1800 | 850 | 700 | kg | <p>Spostamento bozzello in orizzontale Block moving horizontally Bloquer le déplacement horizontal Blockieren horizontal bewegt Bloquear el movimiento horizontal Bloquear moviendo horizontalmente</p> | | | | | | |
| 3 | 19 | 21 | m | | | | | | | | | | | | | |
| 1800 | 850 | 700 | | kg | | | | | | | | | | | | |
|  | <table border="1"> <tr> <td>3</td> <td>22</td> <td>23,8</td> <td rowspan="2">m</td> </tr> <tr> <td>600</td> <td>600</td> <td>600</td> <td>kg</td> </tr> </table> | 3 | 22 | 23,8 | m | 600 | 600 | 600 | kg | <p>Portata costante = 600 Kg Constant load = 600 Kg Charge constante = 600 Kg konstanter Belastung = 600 Kg Carga constante = 600 Kg Carga constante = 600 Kg</p> | | | | | | |
| 3 | 22 | 23,8 | m | | | | | | | | | | | | | |
| 600 | 600 | 600 | | kg | | | | | | | | | | | | |
|  | <table border="1"> <tr> <td>3</td> <td>22</td> <td>23,9</td> <td rowspan="2">m</td> </tr> <tr> <td>600</td> <td>600</td> <td>600</td> <td>kg</td> </tr> </table> | 3 | 22 | 23,9 | m | 600 | 600 | 600 | kg | <p>Portata costante = 600 Kg Constant load = 600 Kg Charge constante = 600 Kg konstanter Belastung = 600 Kg Carga constante = 600 Kg Carga constante = 600 Kg</p> | | | | | | |
| 3 | 22 | 23,9 | m | | | | | | | | | | | | | |
| 600 | 600 | 600 | | kg | | | | | | | | | | | | |
|  | <table border="1"> <tr> <td>3</td> <td>11,2</td> <td>12</td> <td>16</td> <td>20</td> <td>24</td> <td rowspan="2">m</td> </tr> <tr> <td>1800</td> <td>1800</td> <td>1650</td> <td>1155</td> <td>875</td> <td>700</td> <td>kg</td> </tr> </table> | 3 | 11,2 | 12 | 16 | 20 | 24 | m | 1800 | 1800 | 1650 | 1155 | 875 | 700 | kg | |
| 3 | 11,2 | 12 | 16 | 20 | 24 | m | | | | | | | | | | |
| 1800 | 1800 | 1650 | 1155 | 875 | 700 | | kg | | | | | | | | | |
|  | <table border="1"> <tr> <td>3</td> <td>12,5</td> <td rowspan="2">m</td> </tr> <tr> <td>1800</td> <td>1800</td> <td>kg</td> </tr> </table> | 3 | 12,5 | m | 1800 | 1800 | kg | <p>Portata costante = 1800 Kg Constant load = 1800 Kg Charge constante = 1800 Kg konstanter Belastung = 1800 Kg Carga constante = 1800 Kg Carga constante = 1800 Kg</p> | | | | | | | | |
| 3 | 12,5 | m | | | | | | | | | | | | | | |
| 1800 | 1800 | | kg | | | | | | | | | | | | | |

Reazioni – Reactions – Réactions – Eckdrücke – Reacciones – Reações

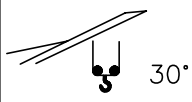
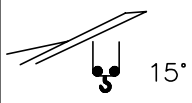
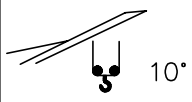
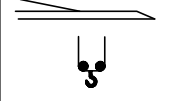
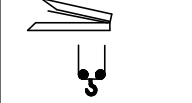
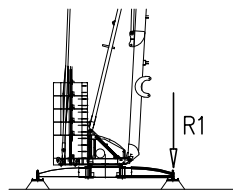

R1 ● 12 t ■ 10 t

▲ 7,1 t ◆ 11,9 t

{ N°2 A=3500Kg (1750Kgx2)
 N°8 B=8400Kg (1050Kgx8)

| | | |
|-------------------------------|---------------------------------------|--------------------------------------|
| ● Reazioni in servizio | ● Reactions in service | ● Réactions en service |
| ■ Reazioni fuori servizio | ■ Reactions out of service | ■ Réactions hors service |
| ▲ Peso della gru senza assali | ▲ Dead weight without transport axles | ▲ Poids de construction sans essieux |
| ◆ Peso zavorra rotante | ◆ Ballast weight | ◆ Poids du lest |

| | | |
|--|--|---|
| ● Reaktionskräfte in betrieb | ● Reacciones en servicio | ● Em serviço |
| ■ Reaktionskräfte außer betrieb | ■ Reacciones fuera de servicio | ■ Fora de serviço |
| ▲ Konstruktionsgewicht ohne transportachse | ▲ Peso de la grua sin tren de transporte | ▲ Peso de la grua sem carro de transporte |
| ◆ Ballastgewicht | ◆ Peso de lastre | ◆ Peso de lastre rotativo |

Montaggio – Montage – Erection – Montage – Montaje – Montagem

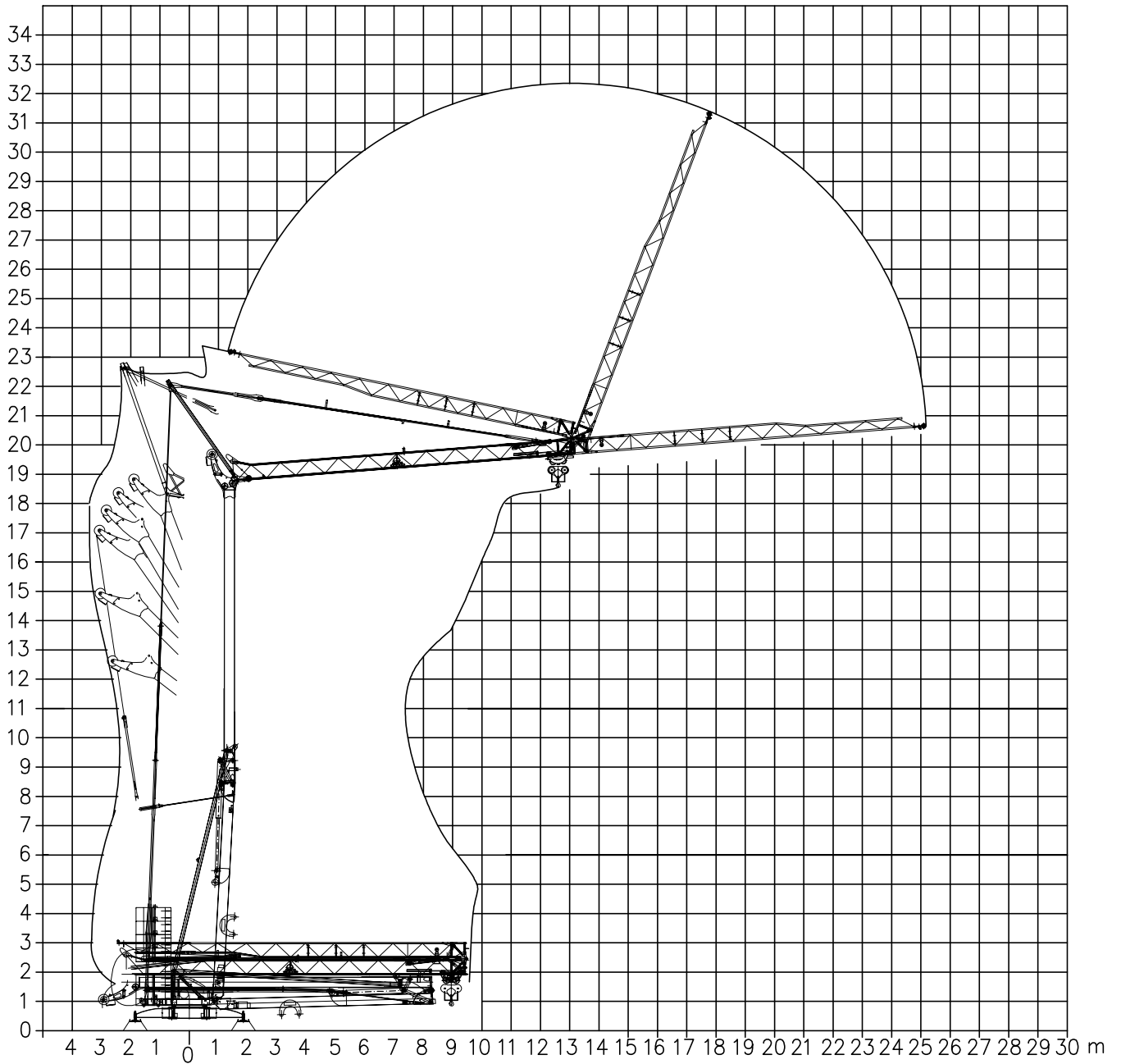

Trasporto – Transport – Transport – Transport – Transporte – Transporte

Trasporto

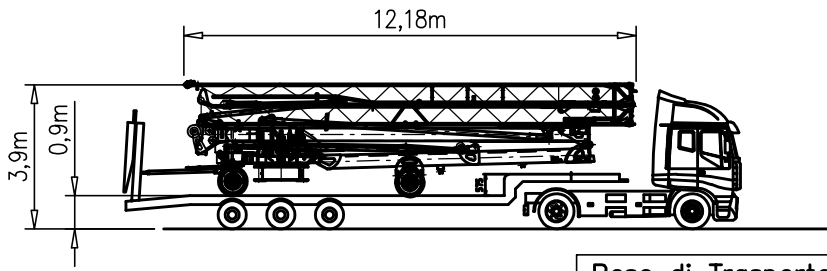

| | |
|---------------------------------------|-------|
| Peso di Trasporto (Solo Blocchi A) Kg | 11360 |
|---------------------------------------|-------|

Traino 5Km/h

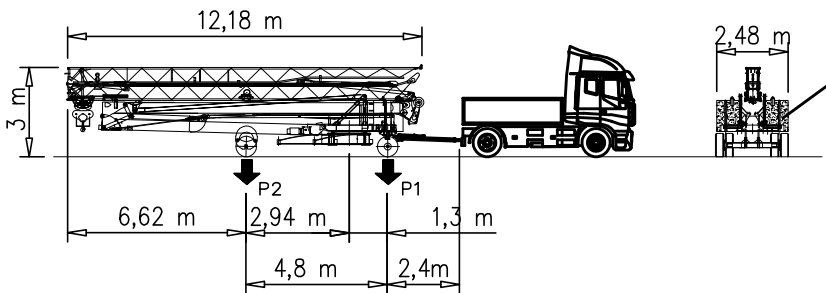

◆ Blocchi A 2x1750=3500 Kg

| | | |
|------|----|-------|
| P1 | Kg | 5060 |
| P2 | Kg | 6300 |
| Ptot | Kg | 11360 |

Traino 25Km/h

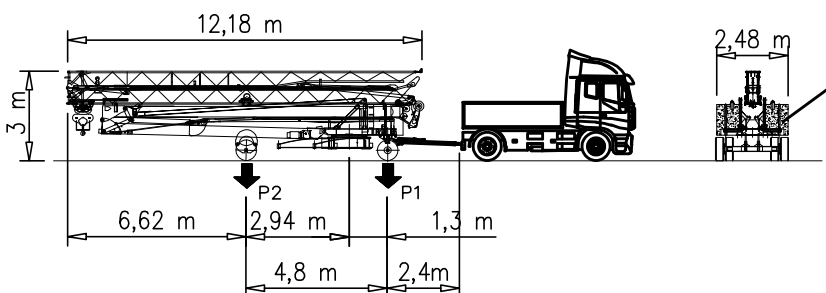

◆ Blocchi A 2x1750=3500 Kg

| | | |
|------|----|-------|
| P1 | Kg | 5490 |
| P2 | Kg | 6300 |
| Ptot | Kg | 12010 |

Traino 80Km/h

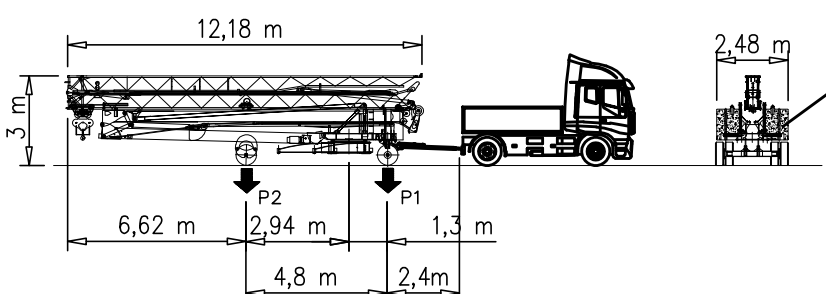

◆ Blocchi A 2x1750=3500 Kg

| | | |
|------|----|-------|
| P1 | Kg | 5990 |
| P2 | Kg | 6820 |
| Ptot | Kg | 12810 |

Traino 80Km/h

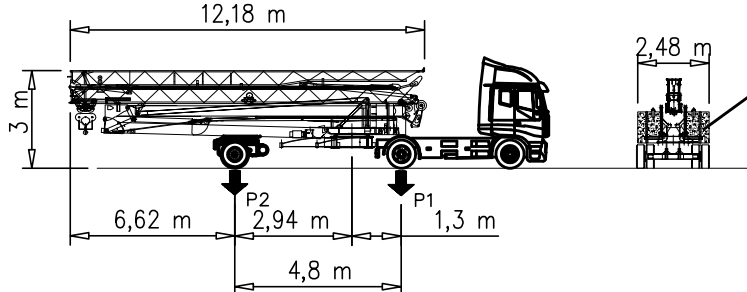

◆ Blocchi A 2x1750=3500 Kg

| | | |
|------|----|-------|
| P1 | Kg | 5990 |
| P2 | Kg | 6820 |
| Ptot | Kg | 12810 |

Meccanismi – Mechanisms – Mécanismes – Antriebe – Mecanismos

| | | | | | | | |
|---|-------|-----|-----|-----|--|--|--|
| V7,5.30 230 Volt Sollevamento Hoisting Levage Heben Elevaciòn Elevaçao | | | | | | | V7,5.30 5.5 kW (7.5 Hp) 2–11 kVA |
| | m/min | 4 | 11 | 25 | | | |
| | t | 1.8 | 1.8 | 0.7 | | | |
| | | | | | | | |
| | | | | | | | |
| | | 4 | 16 | 30 | | | |
| | | 1.8 | 1.8 | 0.7 | | | |

| | | | | | | | |
|---|-------|-----|-----|-----|--|--|--|
| V7,5.30 400 Volt Sollevamento Hoisting Levage Heben Elevaciòn Elevaçao | | | | | | | V7,5.30 5.5 kW (7.5 Hp) 11 kVA |
| | m/min | 4 | 11 | 30 | | | |
| | t | 1.8 | 1.8 | 0.7 | | | |
| | | | | | | | |
| | | | | | | | |
| | | 4 | 16 | 30 | | | |
| | | 1.8 | 1.8 | 0.7 | | | |

| | | | | | | |
|---|--|--|----|---------|------------------------------|---------------|
| Carrello Trolleying Distribuciòn Katzfahren Distribuciòn – Distribuiçao | | | 2a | 0 → 30 | m/min | 2.2 kW (Hp 3) |
| | | | 1a | | | |
| Rotazione Slewing Orientaciòn Schwenken Rotaciòn – Rotaçao | | | 1a | 0 → 0.8 | giri/min tr/min rp/min | 2.2 kW (Hp 3) |
| | | | 2a | | | |
| | | | 3a | | | |

| | |
|--|------------------|
| Rete elettrica – Réseau – Mains supply – Netzstrom – Red – Alimentação | 230/400V – 50 Hz |
|--|------------------|

| | |
|---|----------------|
| Potenza elettrica necessaria – Puissance électrique nécessaire Necessary electric power – Anschlusswert – Potencia electrica necesaria | 1/3PH 2–11 kVA |
|---|----------------|

AFM Gru FMgru s.r.l.
via Emilia 11–29010 Pontenure PC ITALY
tel. 0523/510446 ric.aut. fax 0523/510365
www.fmgru.it e-mail: info@fmgru.com

FEM 1.001–A3
2000/14/CE



Documento commerciale non contrattuale
Per tutte le informazioni tecniche riferirsi
alle corrispondenti istruzioni

Unverbindliches Vertriebsdokument.
Für technische Informationen, siehe die
entsprechenden Anweisungen.

This commercial document is not legally
binding. For any technical information, please
refer to the corresponding instructions.

Documento comercial non contractual
Para cualquier información técnica,
ver la noticia correspondiente.

| | | | |
|--------------------|----------|-----|----------|
| Code: 15ICA37B32A0 | | | |
| Ed. | Data | Rev | Data |
| 1 | 12.04.07 | 4 | 21.03.19 |